

PANDJIRIS, INC

5151 Northrup • St. Louis, MO 63110 • (314) 776-6893

MODEL PR-50/17 TURNING ROLL

The **Model PR-50/17 Turning Roll** has a capacity of 25 tons turning and 8.5 tons support. It features Pandjiris' exclusive torque-tube wheel design sealed bearings, alloy shafts, and totally enclosed fan cooled (TEFC) motors with electronic drives. It comes with field changeable plug-in hand pendants including "Forward-Stop-Reverse-Weld/Rapid" buttons and a speed adjustment potentiometer on 25' of cable. All "PR" models have electronic variable speed controls infinitely variable between a specified range. This product is wired for 230/460 volts, single phase, 60 cycle, draws 15 amps @ 230 VAC. All wiring conforms to National Electrical Code Standards.

Turning Capacity 50,000 lbs.
 Tractive Effort 2,310 lbs.
 Load Capacity 17,000 lbs.
 Pipe Diameter Range 6" thru 15'
 Speed Range 2.1 to 63 IPM
 Motor Horse Power Rating 1.5 HP
 Wheel Diameter 16"
 Combined Wheel Face 8"

The **Model IR-17 Idler Roll** has 8.5 tons support capacity.

Weight Capacity of IR-17 17,000 lbs
 Weight Capacity of (1) PR-50 with (1) IR-17 34,000 lbs
 Weight Capacity of (1) PR-50 with (2) IR-17 50,000 lbs

| | | |
|---|---|----------|
| A | Axle Height | 11-3/8" |
| B | Wheel Height | 19-3/8" |
| C | Wheel Diameter | 16" |
| D | Spacing for Cylinder \varnothing 6" - 41" | 19-1/2" |
| E | Spacing for Cylinder \varnothing 30" - 87" | 35" |
| F | Spacing for Cylinder \varnothing 50" - 132" | 50-1/2" |
| G | Spacing for Cylinder \varnothing 100" - 15' | 66" |
| I | Overall Length of Power Roll | 113-1/2" |

| | | |
|---|---------------------------|---------|
| J | Overall Width Power Roll | 26" |
| K | Frame Width Power Roll | 20" |
| L | Combined Wheel Face | 8" |
| M | Overall Length Idler Roll | 90" |
| N | Axle Height | 11-3/8" |
| O | Wheel Height | 19-3/8" |
| P | Frame Width Idler Roll | 25" |

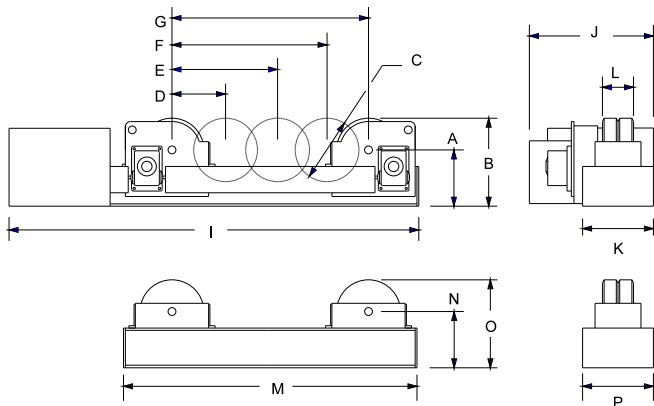

Terms: Pandjiris, Inc. standard terms and conditions apply, f.o.b. Factory, St. Louis, Missouri, or designated ship point.

Delivery: Consult Factory
 Approximate shipping weight:
 PR-50 1,150 lbs.
 IR-17 550 lbs.

| | |
|--------------------|---------------|
| PRICE LIST | |
| For Bulletin No. : | PW-1274 |
| Effective Date : | Nov. 19, 1999 |
| Page Number : | C-21 |

PANDJIRIS, INC

5151 Northrup • St. Louis, MO 63110 • (314) 776-6893

PR SERIES TURNING ROLLS Optional Accessories

For steel wheels in place of rubber wheels

For foot switch with compatible plug for Forward/Stop/Reverse
(speed potentiometer on hand pendant)

For foot switch, Fast-Slow with compatible plug

For preset digital tachometer with compatible plug reads
speed in IPM or CmPM

For 25' Extension Cable with compatible plugs for standard
pendants and accessories

For special voltages, PR-30/10 thru PR-100/34

For special voltages, PR-180/60 thru PR-270/90

For special voltages, PR-400/200 thru PR-480/120

PRICE LIST

For Bulletin No. : PW-1274-A
Effective Date : June 1, 1995
Page Number : C-22