

PANDJIRIS, INC

5151 Northrup • St. Louis, MO 63110 • (314) 776-6893

6,000 LB. CAPACITY TURNTABLE MODEL MT-60-6-VS

The **Model MT-60-6-VS Turntable** is designed to support 6,000 lbs and deliver smooth variable speed table rotation. The turntable comes standard with round a table equipped with (4) radial tee slots. Standard electrical input requirement are 115 volts, single phase, 60 cycle. The operator controls the rotation speed and direction from a hardened plastic hand pendant on 25' of heavy rubber cable. Foot switch controls are available for direction and speed control. All control voltages are 115 volts or less. Wired to conform to National Electrical Code Standards.

Load Capacity 6,000 lbs. @ 6"
 Rotation Torque 4,200 inch pounds
 Rotation Drive 1/3 H.P. DC Motor controlled by an SCR Variable
 Speed Reversing Drive
 Rotation Speed 0.05 to 1.06 RPM
 Control Pendant Forward-Stop-Reverse, Weld/Rapid Push Buttons,
 speed potentiometer on 25' of rubber covered cable.
 Electricals 115 Volt, single phase, 60 Hz input power. Controls are
 115 Volt or less. Wired to National Electrical Code.

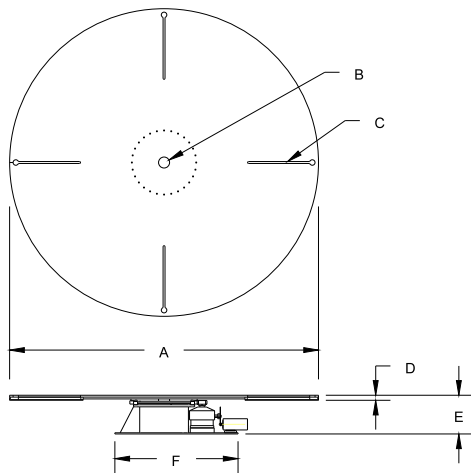

A	Table Diameter	36"	
B	Pilot Hole	2-3/8"	
C	"T-Slot Quantity	(4)	
	Standard ANSI "T" Nut	1/2"	
D	Table Thickness	1/2"	
E	Table Height	15-7/8"	
F	Base Dimensions	Length	29"
		Width	26"

Terms: Pandjiris, Inc. standard terms and conditions apply, f.o.b. Factory, St. Louis, Missouri, or designated ship point.

Delivery: Consult factory.

Approximate Shipping Weight: 560 lbs

PRICE LIST

Effective Date : Jan 16, 1996
 Page Number : I-1

PANDJIRIS, INC

5151 Northrup • St. Louis, MO 63110 • (314) 776-6893

MODEL MT-60-6-VS TURNTABLE Optional Accessories

For precision machined table to include "T" Slots, Pilot Hole, Table Surface

For blanchard grinding of table surface only

Foot switch with compatible plug for Forward/Stop/Reverse
(speed potentiometer on hand pendant)

Foot switch, Fast-Slow with compatible plug

Preset digital tachometer with compatible plug reads speed in RPM

Dialweld®, (shows linear speed in IPM for diameter set on diameter selector.
Dial diameter to be welded, dial weld speed, table RPM is automatically
set to weld diameter at selected welding speed) digital
meter with compatible plug reads IPM or CmPM

Tach feedback for precision speed control

For special voltages

25' Extension Cable with compatible plugs for standard
pendants and accessories

Model 600 PT Copper Welding Ground

Model 1200 PT Copper Welding Ground

Terms: Pandjiris, Inc. standard terms and
conditions apply, f.o.b. Factory, St. Louis,
Missouri, or designated ship point.

Delivery: Consult Factory

PRICE LIST

For Bulletin No. :
Effective Date : August 9, 1999
Page Number : I-2