

PANDJIRIS, INC

5151 Northrup • St. Louis, MO 63110 • (314) 776-6893

40,000 LB. CAPACITY WELDING POSITIONER

The Model 400-12 MVRMTAB Positioner has a motorized variable speed rotation with Forward-Stop-Reverse switch and dynamic braking. The rotation speed is variable from 0.01 to .50 RPM with motorized tilt infinitely variable through 135 degrees. An 84" square table with adjustable height to allow full tilting capability is standard. Five positions with pinned hole locations. All wiring conforms to National Electrical Code Standards. The positioner operates on 460-volt, three phase, 60 cycle input power, 25 amps (230V, 40 amps, available upon request). When ordering specify 230 or 460 volts. A field changeable plug-in hand pendant includes "Forward-Stop-Reverse-Weld/Rapid-E-Stop" buttons and a speed adjustment potentiometer on 25' of cable as standard. Tilt Up/Down Pushbuttons located on the side of the main electrical enclosure. Control voltage is 24 VAC. Equipment is high frequency protected.

Load capacity40,000 lb. 12-inch overhung from face of table, 12-inch eccentricity.
Rotational motor size..... 10 H.P. motor.
Rotation speedVariable from 0.01 to 0.50 RPM.
Rotation torque (R_t)480,000-inch pounds.
Swing radius54" to 102" @ 90° tilt
Tilt range0 through 135 degrees, motorized.
Tilt motor size7-1/2 H.P. AC Brakemotor.
Tilt Speed135 degrees in 95 seconds.
Tilt Torque (T_t)1,170,000-inch pounds inherent.

The Model 400-12 MVRMT-VPL Positioner is the same as Adjustable Base unit except with vertical power lift via **dual acme screw lift**, linear rail guide bearings, 7 ½hp Brakemotor, 20 IPM, overtravel limit switch protection. Up/Down push buttons momentary contact located in the side of the electrical enclosure next to the Tilt Up/Down push buttons. **84" square** table height infinitely adjustable between 80" and 110" above floor line. Rotation Centerline at 90 degrees forward tilt is 68" to 98" above the floor line with swing radius at 64" to 86".

Optional Accessories

Foot switch with compatible plug for Forward/Stop/Reverse (speed potentiometer on hand pendant)
Foot switch, Variable Speed with compatible plug
Preset digital tachometer with compatible plug reads speed in RPM
Dialweld®, (shows linear speed in IPM for diameter set on diameter selector. Dial diameter to be welded, dial weld speed, table RPM is automatically set to weld diameter at selected welding speed) digital meter with compatible plug reads IPM or CmPM
25' Extension Cable with compatible plugs for standard pendants and accessories
Model 600 PT Copper Welding Ground
Model 1200 PT Copper Welding Ground
Encoder Feedback for Precision Speed Control
Hand Pendant with Tilt Up/Down in Addition to Standard Features, In Lieu of Standard Pendant
Wireless Foot Switch or Wireless Hand Pendant

Terms: Pandjiris, Inc. standard terms and conditions apply, f.o.b. Factory, St. Louis, Missouri, or designated ship point.

Delivery: Consult Factory

Approximate shipping weight: 24,400 lbs.

PRICE LIST

For Bulletin No. : PC 0991
Effective Date : October 2020
Page Number : A-27

PANDJIRIS, INC

5151 Northrup • St. Louis, MO 63110 • (314) 776-6893

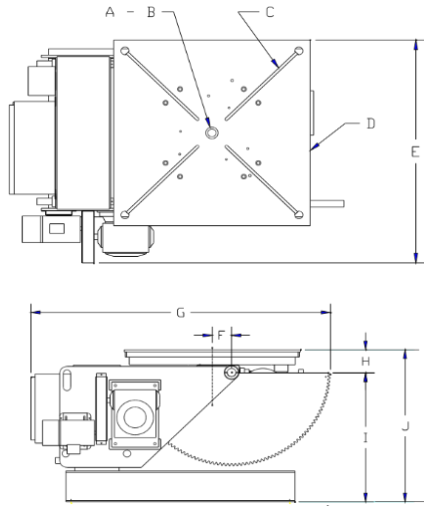

A	Pilot Hole	5.00" ϕ x 1/4" Deep
B	Thru Hole	None
C	"T" Slot Quantity	4
	ANSI Std "T" Nut size	1-1/4"
D	Table Size	84" sq.
E	Overall Width	106-7/16"
F	Rotation Offset	0"
G	Overall Length	150-1/2"
H	Inherent Overhang	12"
I	Tilt Axis Height	58-1/4"
J	Table Height min	70-5/16"
	(5) Positions max	114-5/16"

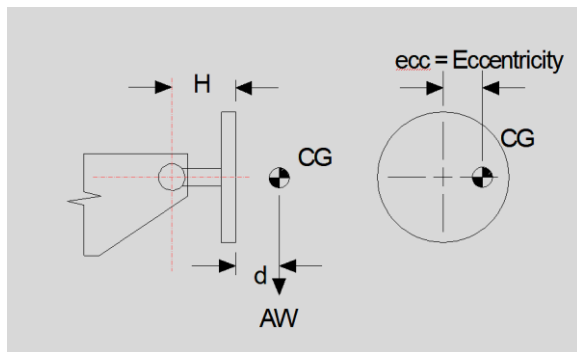

RATED OVERHUNG LOAD	
d (inches)	AW (pounds)
0 to 12	40,000
18	33,191
24	28,364
30	24,762
36	21,972
42	19,747
48	17,931

Terms: Pandjiris, Inc. standard terms and conditions apply, f.o.b. Factory, St. Louis, Missouri, or designated ship point.

Delivery: Consult Factory

Approximate shipping weight: 24,400 lbs.

PRICE LIST

For Bulletin No. : PC 0991
 Effective Date : October 2020
 Page Number : A-28