

# PANDJIRIS, INC

5151 Northrup • St. Louis, MO 63110 • (314) 776-6893

## 60,000 LB. CAPACITY WELDING POSITIONER (MODEL 600-12)

**The Model 600-12 MVRMTAB Positioner** has a motorized variable speed rotation with Forward-Stop-Reverse switch and dynamic braking. The rotation speed is variable from 0.017 to .50 RPM with motorized tilt infinitely variable through 135 degrees. An 96" square table with adjustable height to allow full tilting capability is standard. . Five positions with pinned hole locations. All wiring conforms to National Electrical Code Standards. The positioner operates on 460-volt, three phase, 60 cycle input power, 25 amps (230V, 40 amps, available upon request). When ordering specify 230 or 460 volts. A field changeable plug-in hand pendant includes "Forward-Stop-Reverse-Weld/Rapid-E-Stop" buttons and a speed adjustment potentiometer on 25' of cable as standard. Tilt Up/Down Pushbuttons located on the side of the main electrical enclosure. Control voltage is 24 VAC. Equipment is high frequency protected.

Load capacity..... 60,000 lb. 12-inch overhung from face of table, 12-inch eccentricity.  
Rotational motor size ..... 10 H.P. motor.  
Rotation speed..... Variable from 0.017 to 0.50 RPM.  
Rotation torque (R<sub>t</sub>)..... 720,000-inch pounds.  
Swing radius ..... 78-1/4" to 112-3/16" @ 90° tilt  
Tilt range..... 0 through 135 degrees, motorized.  
Tilt motor size ..... 10 H.P. AC Brakemotor.  
Tilt Speed..... 135 degrees in 87 seconds.  
Tilt Torque (T<sub>t</sub>) ..... 1,200,000-inch pounds inherent.

### Optional Accessories

Foot switch with compatible plug for Forward/Stop/Reverse (speed potentiometer on hand pendant)  
Foot switch, Variable Speed with compatible plug  
Preset digital tachometer with compatible plug reads speed in RPM  
Dialweld® (shows linear speed in IPM for diameter set on diameter selector. Dial diameter to be welded, dial weld speed, table RPM is automatically set to weld diameter at selected welding speed) digital meter with compatible plug reads IPM or CmPM  
25' Extension Cable with compatible plugs for standard pendants and accessories  
Model 600 PT Copper Welding Ground  
Model 1200 PT Copper Welding Ground  
Powered Elevation of Table Height  
Encoder Feedback for Precision Speed Control  
Hand Pendant with Tilt Up/Down in Addition to Standard Features, In Lieu of Standard Pendant  
Wireless Foot Switch or Wireless Hand Pendant

**Terms:** Pandjiris, Inc. standard terms and conditions apply, f.o.b. Factory, St. Louis, Missouri, or designated ship point.

**Delivery:** Consult Factory

Approximate shipping weight: 25,750 lbs.

#### PRICE LIST

For Bulletin No. : PC 0991  
Effective Date : April 2020  
Page Number : A-29

# PANDJIRIS, INC

5151 Northrup • St. Louis, MO 63110 • (314) 776-6893

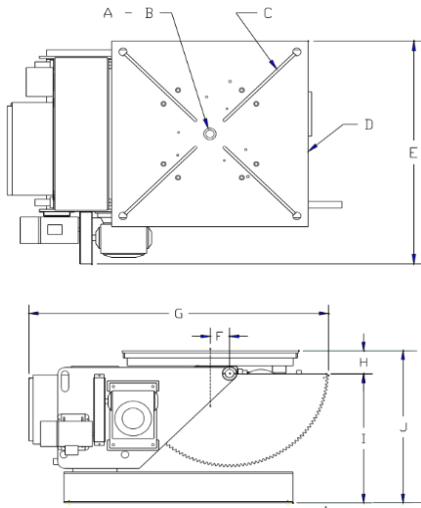

A	Pilot Hole	5.00" $\phi$ x 3/4" Deep
B	Thru Hole	None
C	"T" Slot Quantity	4
	ANSI Std "T" Nut size	1-1/2"
D	Table Size	96" sq.
E	Overall Width	120"
F	Rotation Offset	0"
G	Overall Length	150"
H	Inherent Overhang	8"
I	Tilt Axis Height	72"
J	Table Height min	80"
	(5) Positions max	120"

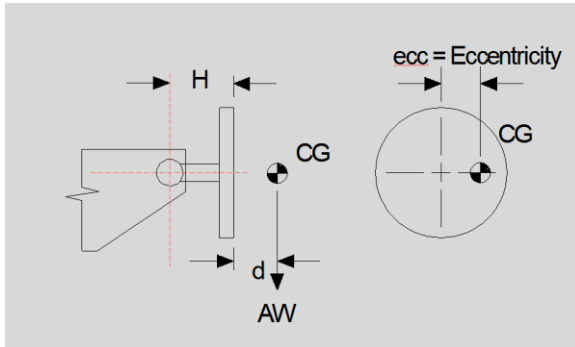

## RATED OVERHUNG LOAD

d (inches)	AW (pounds)
0 to 12	60,000
18	46,154
24	37,500
30	31,579
36	27,273
42	24,000
48	21,429

**Terms:** Pandjiris, Inc. standard terms and conditions apply, f.o.b. Factory, St. Louis, Missouri, or designated ship point.

**Delivery:** Consult Factory

Approximate shipping weight: 25,750 lbs.

## PRICE LIST

For Bulletin No. : PC 0991  
 Effective Date : April 2020  
 Page Number : A-30