

Manufactured in U.S.A.

PANDJIRIS,® INC.

#1 in Fixed Welding Automation

PIPP PARTNERS IN POSITIONING & PROFITS

PRODUCT BULLETIN FOR LINCOLN PARTNERS

July 2008

PANDJIRIS/LINCOLN TEAMWORK SINGLE SOURCE AUTOMATION SOLUTION

The Lincoln Electric - Pandjiris Partnership and value-added relationship creates consumable orders for Lincoln by bringing new welding and positioning equipment solutions to the end user and the welding industry. This Teamwork produced another success story combining Lincoln's latest state-of-the-art Power Wave AC/DC Welding Technology with Pandjiris precision and quality hard automation positioning equipment.

A major U.S. manufacturer of lift trucks was looking for a fully automated turnkey solution and system to improve its product quality, boost its production and maximize profitability. This system was to perform synchronous (two welding heads) or single head longitudinal fillet welds on masts for lift trucks. Pandjiris designed a 40' heavy duty side beam and carriage system which transports the weld heads and precision controls over parts supported between a head and tailstock. Tactile seam trackers are utilized to maintain torch positions relative to the weld joint. Flux recovery and feed systems are provided to support Lincoln Electric's Power Wave AC/DC Saw Welding Packages.

The Pandjiris Model 40-24 Welding Carriage supports up to 4,000 pounds at up to 24" from the face of the carriage. The carriage has a speed range of 6 to 180 IPM and the side beam allows up to 35' of travel. A 24" vertical slide is provided for each weld head to provide additional elevation beyond the capabilities of the seam tracker slides. The weld heads and seam tracker cross slides are mounted on manual carriages to allow adjustment of the spacing between the welding torches of 5" to 48" from tip to tip. Impingement swivels were provided to allow adjustment of the weld head angle.

The Pandjiris Model HTS-60, 6,000 pound capacity head and tailstock, was used to support and orient the parts for welding. A Pandjiris Model 3042 travel car was provided for the tailstock to adjust for various part lengths.

This Fully Automated Heavy Duty Side Beam System with Power Wave AC/DC Saw Welding Package was integrated and the end user's operators and supervisors were trained by Pandjiris both in the operation of the new Lincoln Power Wave Control Technology and Automated Positioning System.

The Lincoln-Panjiris Partnership offers the best value-added automation solutions and integrated positioning systems in the world and creates consumable orders for The Lincoln Electric Company.

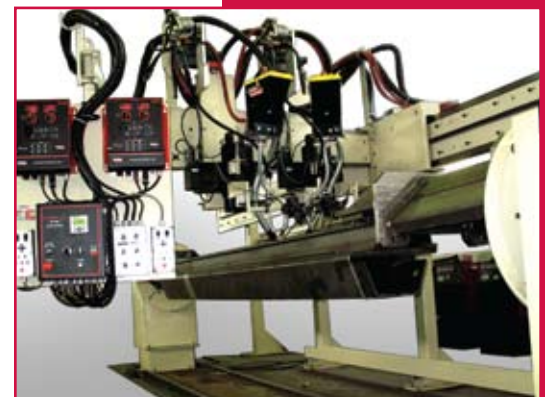
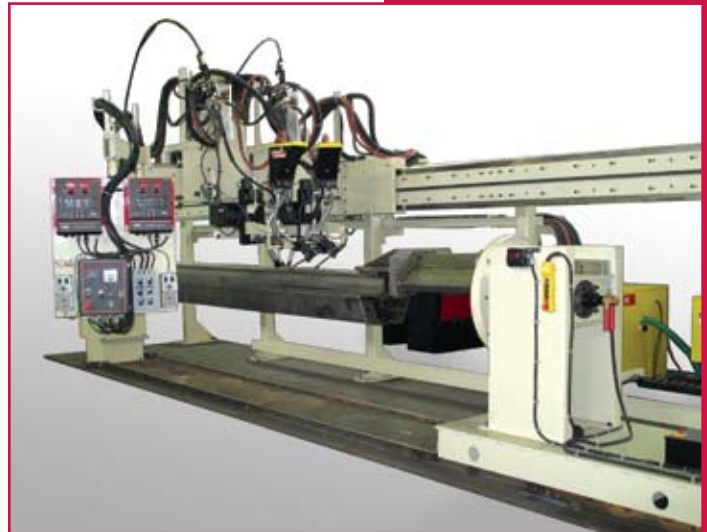

PANDJIRIS® SIDE BEAMS & CARRIAGES

HEAVY DUTY SIDE BEAM TRACK WITH RACK & PINION DRIVE CARRIAGES AND NEW EZ LINK® SERIES CONTROLLERS

Utilizing Pandjiris' heavy duty side beam and rack and pinion carriage, Lincoln can provide their customers a fully integrated and automated turnkey system for increasing sales of both equipment and welding consumable products.

SYSTEM FEATURES

- Adaptable for all Lincoln's welding processes: Sub-Arc, Mig, Tig (single, tandem, and triple arc).
- Any length side beam system can be provided for applications.
- Positive rack and pinion drive carriage to provide smooth travel and eliminate slippage.
- Three (3) sizes of variable speed carriages (see below)
- Pandjiris EZ Link® PLC-Based Controllers for automated equipment control function; weld start/stop and auto travel integration.
- Carriages can support accessories such as heavy duty slides, controls and flux recovery systems.
- Pandjiris stanchions for side beam support. Manual or powered height adjustment available.
- Power cable track for cables and hoses available.

BENEFITS

- Value-added single source solutions and systems
- Turnkey capability for both the customer and distributor
- Complementing the latest welding technology with state-of-the-art positioning equipment
- Increases productivity, operator efficiency and lowers manufacturing cost

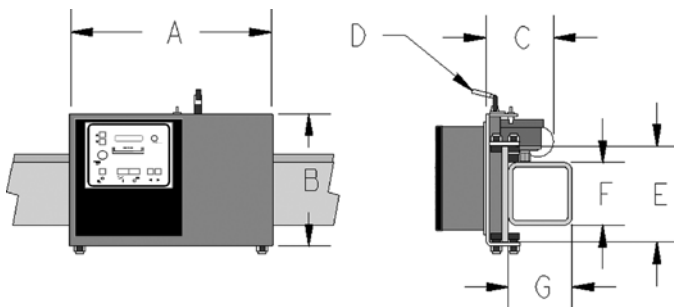
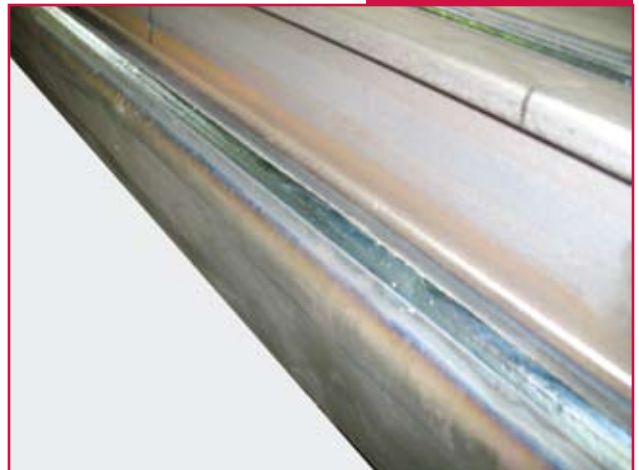

	A	B	C	D	E	F	G
VSC-15-3	26-1/4"	17"	8-1/2"	Disengage Lever	12"	8"	6"
VSC-21-12	26-14"	17"	10"	Optional	12"	8"	6"
VSC-40-12	48-3/4"	20"	6-5/8"	N/A	14-1/2"	10"	10"

*Pandjiris Side Beam
System integrated with
Lincoln Powerwave AC/
DC SAW Weld Package*