

PANDJIRIS, INC

5151 Northrup • St. Louis, MO 63110 • (314) 776-6893

MM-15/5-T TURNING ROLL

The **MM-15/5-T Power Roll** has a capacity of 15 tons turning and 5 tons support with a speed range of 2.1 to 63.5 IPM. It provides a constant centerline of operation while requiring less floor space than other rolls their size, and are easily changeable for varying size tank diameters. A unique and exclusive drive roll connection is positively driven by spur gears for a firm power flow. All "MM" rolls have electronic variable speed controls infinitely variable between a specified range. They also all come with a field changeable plug-in hand pendant, including "Forward-Stop-Reverse-Weld/Rapid" buttons and a speed potentiometer on 25' of cable. **The Rolls operate on 120 volt, single phase, 60 cycle input power**, All wiring conforms to National Electrical Code Standards.

Turning Capacity30,000 lbs.
 Tractive Effort1,385 lbs
 Load Capacity10,000 lbs.
 Pipe Diameter Range4" thru 144"
 Speed Range2.1 to 63.5 IPM
 Motor Horse Power Rating1 HP
 Wheel Diameter16"
 Combined Wheel Face4"

The MI-5-T Idler Roll has 5 tons support capacity.

Weight Capacity of (1) MM-15 and (1) MI-5-T 10 tons
 Weight Capacity of (1) MM-15 and (2) MI-5-T 15 tons

A	Wheel Height	32.11"	G	Spacing for Cylinder ϕ 58" - 92"	18.55"
B	Wheel Height	31.38"	H	Spacing for Cylinder ϕ 72" - 144"	22.00"
C	Wheel Height	28.88"	I	Wheel Diameter	16"
D	Wheel Height	24.94"	J	Wheel Face	4"
E	Spacing for Cylinder ϕ 4" - 36"	8.75"	K	Frame Length - Power or Idler	61.25"
F	Spacing for Cylinder ϕ 35" - 65"	13.94"	L	Frame Width - Power or Idler	29.25"

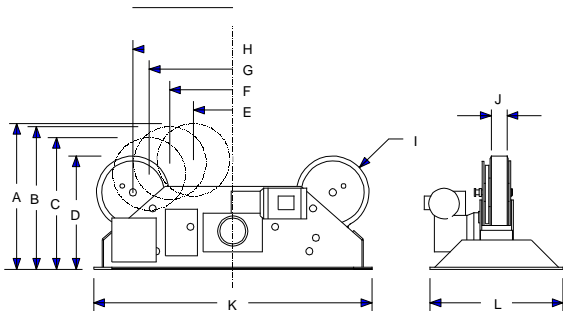

Terms: Pandjiris, Inc. standard terms and conditions apply, f.o.b. Factory, St. Louis, Missouri, or designated ship point.

Delivery: Consult Factory

Approximate shipping weight:
 MM-15 1,050 lbs.
 MI-5-T 500 lbs.

PRICE LIST

For Bulletin No. : 15367-A
 Effective Date : Sept 1, 2016
 Page Number : C-11

PANDJIRIS, INC

5151 Northrup • St. Louis, MO 63110 • (314) 776-6893

MISSOURI MULE TURNING ROLL Optional Accessories

NOTE: For steel wheels in place of rubber tires on all rolls listed Consult Factory

For foot switch with compatible plug for Forward/Stop/Reverse (speed potentiometer on hand pendant)

For foot switch, Fast-Slow with compatible plug

For preset digital tachometer with compatible plug reads speed in IPM or CmPM

For 25' Extension Cable with compatible plugs for standard pendants and accessories

For Riser for Power Roll to Match Height of Idler Roll on Casters

For Casters for Power Roll

For Casters for Idler Roll

For Model VT Track, add per 10' Section

For special voltages on MM-15/5T & MM-30/15T

For special voltages on MM-60/30T

For special voltages on MM-90/45T

PRICE LIST

For Bulletin No. : 15367-A
Effective Date : Sept 1, 2016
Page Number : C-12