

PANDJIRIS, INC

5151 Northrup • St. Louis, MO 63110 • (314) 776-6893

MM-90/45-T TURNING ROLL

The **MM-90/45-T Power Roll** has a capacity of 90 tons turning and 45 tons support with a speed range of 2 to 61.4 IPM. It provides a constant centerline of operation while requiring less floor space than other rolls their size, and are easily changeable for varying size tank diameters. A unique and exclusive drive roll connection is positively driven by spur gears for a firm power flow. All "MM" rolls have electronic variable speed controls infinitely variable between a specified range. They also all come with a field changeable plug-in hand pendant, including "Forward-Stop-Reverse-Weld/Rapid" buttons and a speed potentiometer on 25' of cable. The Rolls operate on 460 volt, three phase, 60 cycle input power, (230V available upon request). When ordering specify 230 or 460 volts All wiring conforms to National Electrical Code Standards.

Turning Capacity 180,000 lbs.
 Tractive Effort 8,314 lbs.
 Load Capacity 90,000 lbs.
 Pipe Diameter Range 12" thru 16'
 Speed Range 2 to 61.4 IPM
 Motor Horse Power Rating 5 HP
 Wheel Diameter 20"
 Combined Wheel Face 32"

The **MI-45-T Idler Roll** has 45 tons support capacity each.

Weight Capacity of (1) MM-90 and (1) MI-45-T 90 tons

A	Wheel Height	40.12"	G	Spacing for Cylinder i 100" - 156"	30.00"
B	Wheel Height	42.16"	H	Spacing for Cylinder i 122" - 192"	35.63"
C	Wheel Height	39.74"	I	Wheel Diameter	20"
D	Wheel Height	33.79"	J	Overall Wheel Face	32"
E	Spacing for Cylinder i 12" - 62"	13.75"	K	Frame Length - Power or Idler	94"
F	Spacing for Cylinder i 60" - 102"	20.87"	L	Frame Width - Power/Idler	47"/38"

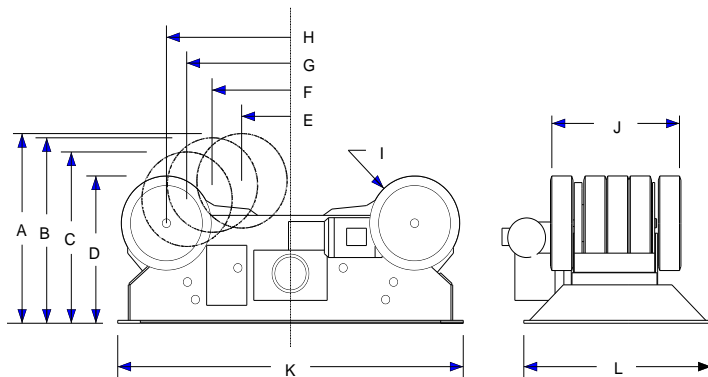

Terms: Pandjiris, Inc. standard terms and conditions apply, f.o.b. Factory, St. Louis, Missouri, or designated ship point.

Delivery: Consult Factory

Approximate shipping weight:
 MM-90 4,500 lbs.
 MI-45-T 2,800 lbs.

PRICE LIST

For Bulletin No. : 15367-A
 Effective Date : January 2014
 Page Number : C-17

PANDJIRIS, INC

5151 Northrup • St. Louis, MO 63110 • (314) 776-6893

MISSOURI MULE TURNING ROLL Optional Accessories

NOTE: For steel wheels in place of rubber tires on all rolls listedConsult Factory

For foot switch with compatible plug for Forward/Stop/Reverse (speed potentiometer on hand pendant)

For foot switch, Fast-Slow with compatible plug

For preset digital tachometer with compatible plug reads speed in IPM or CmPM

For 25' Extension Cable with compatible plugs for standard pendants and accessories

For Riser for Power Roll to Match Height of Idler Roll on Caster

For V-groove, Spring Loaded Casters for Power Roll

For V-groove, Spring Loaded casters for Idler Roll

For Model VT Track, add per 10' section

For special voltages on MM-15/5-T & MM-30/15-T

For special voltages on MM-60/30-T

For special voltages on MM-90/45-T

PRICE LIST

For Bulletin No. : 15367-A
Effective Date : January 2014
Page Number : C-18