

PANDJIRIS, INC

5151 Northrup • St. Louis, MO 63110 • (314) 776-6893

12,000 LB. CAPACITY TURNTABLE MODEL MT-120-4.5-VS

The **Model MT-120-4.5-VS Turntable** is designed to support 12,000 lbs and deliver smooth variable speed table rotation. The turntable comes standard with a round table equipped with (4) radial tee slots. Standard electrical input requirement is 115 Volt, single phase, 60 cycle. The operator controls the rotation speed and direction from a hardened plastic hand pendant on 25' of heavy rubber cable. Foot switch controls are available for direction and speed control. All control voltages are 115 volts or less. Wired to conform to National Electrical Code Standards.

- Load Capacity 12,000 lbs. @ 4.5"
- Rotation Torque 18,500 inch pounds
- Rotation Drive 1/2 H.P. DC Motor controlled by an SCR Variable Speed Reversing Drive
- Rotation Speed 0.031 to .630 RPM
- Control Pendant Forward-Stop-Reverse, Weld/Rapid Push Buttons, speed potentiometer on 25' of rubber covered cable.
- Electricals 115 Volt, single phase, 60 Hz input power. Controls are 115 Volt or less. Wired to National Electrical Code.

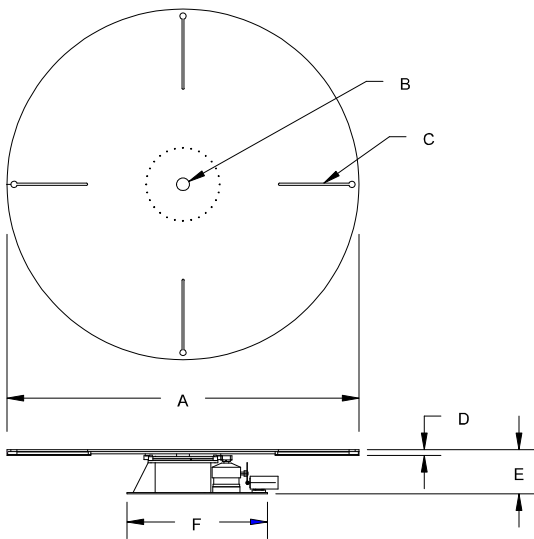

A	Table Diameter	48"	
B	Pilot Hole	2-3/8"	
C	"T" Slot Quantity	(4)	
	Standard ANSI "T" Nut	3/4"	
D	Table Thickness	5/8"	
E	Table Height	16-13/16"	
F	Base Dimensions	Length	36"
		Width	32"

Terms: Pandjiris, Inc. standard terms and conditions apply, f.o.b. Factory, St. Louis, Missouri, or designated ship point.

Delivery: Consult factory.

Approximate Shipping Weight: 1,500 lbs

PRICE LIST

For Bulletin No. :
Effective Date : January 2014
Page Number : I-3

PANDJIRIS, INC

5151 Northrup • St. Louis, MO 63110 • (314) 776-6893

MODEL MT-120-4.5-VS TURNTABLE Optional Accessories

For precision machined table to include "T" Slots, Pilot Hole, Table Surface

For blanchard grinding of table surface only

Foot switch with compatible plug for Forward/Stop/Reverse
(speed potentiometer on hand pendant)

Foot switch, Fast-Slow with compatible plug

Preset digital tachometer with compatible plug reads speed in RPM

Dialweld®, (shows linear speed in IPM for diameter set on diameter selector.
Dial diameter to be welded, dial weld speed, table RPM is automatically
set to weld diameter at selected welding speed) digital
meter with compatible plug reads IPM or CmPM

Tach feedback for precision speed control

For special voltages

25' Extension Cable with compatible plugs for standard pendants and accessories

Model 600 PT Copper Welding Ground

Model 1200 PT Copper Welding Ground