

PANDJIRIS, INC

5151 Northrup • St. Louis, MO 63110 • (314) 776-6893

120,000 LB. CAPACITY TURNTABLE MODEL MT-1200-12-VS

The **Model MT-1200-12-VS Turntable** is designed to support 120,000 lbs and deliver smooth variable speed table rotation. The turntable comes standard with a round table equipped with (4) radial tee slots. Standard electrical input requirement are 230 or 460 volts, 3 phase, 60 cycle. The operator controls the rotation speed and direction from a hardened plastic hand pendant on 25' of heavy rubber cable. Foot switch controls are available for direction and speed control. All control voltages are 115 volts or less. Wired to conform to National Electrical Code Standards.

Load Capacity 120,000 lbs. @ 12"
 Rotation Torque 107,000 inch pounds
 Rotation Drive 1 H.P. DC Motor controlled by an SCR Variable
 Speed Reversing Drive
 Rotation Speed 0.007 to 0.20 RPM
 Control Pendant Forward-Stop-Reverse, Weld/Rapid Push Buttons,
 speed potentiometer on 25' of rubber covered cable.
 Electricals 230/460 Volt, 3-phase, 60 Hz input power. Controls are 115 Volt
 or less. Wired to National Electrical Code.

MODEL MT-1200-12-VS (Variable Speed)

MODEL MT-1200-12-CS (Constant Speed 0.20 RPM)

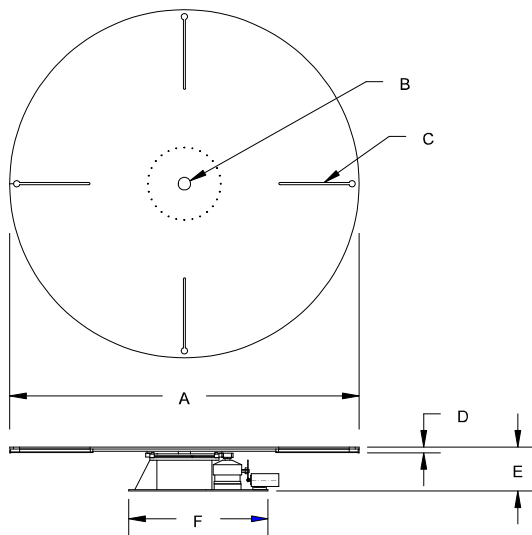

A	Table Diameter	72"	
B	Pilot Hole	6"	
C	"T" Slot Quantity	(4)	
	Standard ANSI "T" Nut	1"	
D	Table Thickness	1-7/8"	
E	Table Height	18-5/8"	
F	Base Dimensions	Length	68"
		Width	56"

Terms: Pandjiris, Inc. standard terms and conditions apply, f.o.b. Factory, St. Louis, Missouri, or designated ship point.

Delivery: Consult factory.

Approximate Shipping Weight: 4,200 lbs

PRICE LIST

For Bulletin No. :
 Effective Date : January 2014
 Page Number : I-11

PANDJIRIS, INC

5151 Northrup • St. Louis, MO 63110 • (314) 776-6893

**MODEL MT-1200-12-VS TURNTABLE
Optional Accessories**

For precision machined table to include "T" Slots, Pilot Hole, Table Surface Consult Factory

For blanchard grinding of table surface only, add Consult Factory

Foot switch with compatible plug for Forward/Stop/Reverse (speed potentiometer on hand pendant)

Foot switch, Fast-Slow with compatible plug

Preset digital tachometer with compatible plug reads speed in RPM

Dialweld®, (shows linear speed in IPM for diameter set on diameter selector.
Dial diameter to be welded, dial weld speed, table RPM is automatically
set to weld diameter at selected welding speed) digital
meter with compatible plug reads IPM or CmPM

Tach feedback for precision speed control

For special voltages, add Consult Factory

25' Extension Cable with compatible plugs for standard
pendants and accessories

Model 600 PT Copper Welding Ground

Model 1200 PT Copper Welding Ground

Terms: Pandjiris, Inc. standard terms and
conditions apply, f.o.b. Factory, St. Louis,
Missouri, or designated ship point.

Delivery: Consult Factory

PRICE LIST	
For Bulletin No.	:
Effective Date	: January 2014
Page Number	: I-12