

PANDJIRIS, INC

5151 Northrup • St. Louis, MO 63110 • (314) 776-6893

40,000 LB. CAPACITY TURNTABLE MODEL MT-400-12-VS

The **Model MT-400-12-VS Turntable** is designed to support 40,000 lbs and deliver smooth variable speed table rotation. The turntable comes standard with a round table equipped with (4) radial tee slots. Standard electrical input requirement are 115 volts, 1 phase, 60 cycle. The operator controls the rotation speed and direction from a hardened plastic hand pendant on 25' of heavy rubber cable. Foot switch controls are available for direction and speed control. Wired to conform to National Electrical Code Standards.

- Load Capacity 40,000 lbs. @ 12"
- Rotation Torque 53,500 inch pounds
- Rotation Drive 3/4 H.P. DC Motor controlled by an SCR Variable
Speed Reversing Drive
- Rotation Speed 0.03 to .63 RPM
- Control Pendant Forward-Stop-Reverse, Weld/Rapid Push Buttons,
speed potentiometer on 25' of rubber covered cable.
- Electricals 115 Volt, 1-phase, 60 Hz input power.

MODEL MT-400-12-VS (Variable Speed)

MODEL MT-400-12-CS (Constant Speed 0.63 RPM)

Electricals 230/460 Volt, 3 phase, 60 Hertz

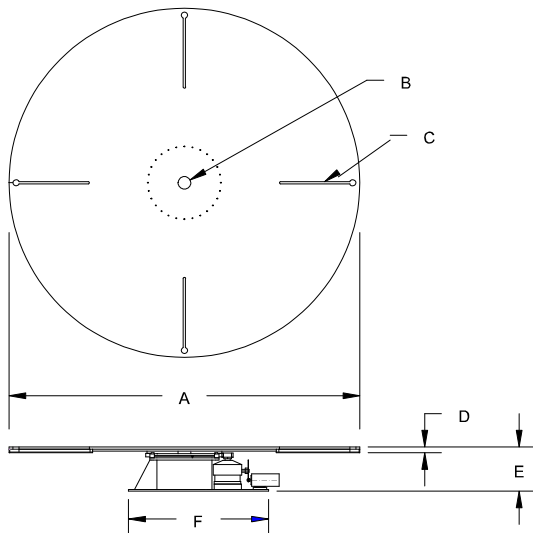

A	Table Diameter	60"	
B	Pilot Hole	6"	
C	"T" Slot Quantity	(4)	
	Standard ANSI "T" Nut	3/4"	
D	Table Thickness	1-3/4"	
E	Table Height	24-3/8"	
F	Base Dimensions	Length	42"
		Width	34"

Terms: Pandjiris, Inc. standard terms and conditions apply, f.o.b. Factory, St. Louis, Missouri, or designated ship point.

Delivery: Consult factory.

Approximate Shipping Weight: 3,000 lbs

PRICE LIST

For Bulletin No. :
Effective Date : January 2014
: I-7

PANDJIRIS, INC

5151 Northrup • St. Louis, MO 63110 • (314) 776-6893

**MODEL MT-400-12-VS TURNTABLE
Optional Accessories**

For precision machined table to include "T" Slots, Pilot Hole, Table Surface, Consult Factory

For blanchard grinding of table surface only, add Consult Factory

Variable Speed Options

Foot switch with compatible plug for Forward/Stop/Reverse
(speed potentiometer on hand pendant)

Foot switch, Fast-Slow with compatible plug

Preset digital tachometer with compatible plug reads speed in RPM

Dialweld®, (shows linear speed in IPM for diameter set on diameter selector.
Dial diameter to be welded, dial weld speed, table RPM is automatically
set to weld diameter at selected welding speed) digital
meter with compatible plug reads IPM or CmPM

Tach feedback for precision speed control

25' Extension Cable with compatible plugs for standard pendants and accessories

For special voltages, (Other than 115 Volt, Variable Speed &
230/460 Volt, Constant Speed), add CONSULT FACTORY

Model 600 PT Copper Welding Ground

Model 1200 PT Copper Welding Ground