

# PANDJIRIS, INC

5151 Northrup • St. Louis, MO 63110 • (314) 776-6893

## MODEL PR-10/5 TURNING ROLL

The **Model PR-10/5 Turning Roll** has a capacity of 5 tons turning and 2-1/2 tons support. It features Pandjiris' heavy duty wheel design, sealed bearings, solid shafts, and totally enclosed fan cooled (TEFC) motors with electronic drives. It comes with field changeable plug-in hand pendants including "Forward-Stop-Reverse-Weld/Rapid" buttons and a speed adjustment potentiometer on 25' of cable. All "PR" models have electronic variable speed controls infinitely variable between a specified range. This product is wired for 115 volts, single phase, 60 cycle, draws 6.5 amps @ 115 VAC. All wiring conforms to National Electrical Code Standards.

Turning Capacity ..... 10,000 lbs.  
 Tractive Effort ..... 462 lbs.  
 Load Capacity ..... 5,000 lbs.  
 Pipe Diameter Range ..... 8" thru 12"  
 Speed Range ..... 3.0 to 80.0 IPM  
 Motor Horse Power Rating ..... 1/3 HP  
 Wheel Diameter ..... 12"  
 Combined Wheel Face ..... 4"

The **Model IR-5 Idler Roll** has 2-1/2 tons support capacity.

Weight Capacity of IR-5 ..... 5,000 lbs  
 Weight Capacity of (1) PR-10 with (1) IR-5 ..... 10,000 lbs

A	Axle Height	8-7/8"
B	Wheel Height	14-7/8"
C	Wheel Diameter	12"
D	Spacing for Cylinder i 8" - 30"	16-1/2"
E	Spacing for Cylinder i 30" - 66"	30"
F	Spacing for Cylinder i 66" - 100"	45"
G	Spacing for Cylinder i 100" - 144"	60"
H	Overall Length of Power Roll	98"

I	Overall Width Power Roll	21-5/8"
J	Frame Width Power Roll	17-5/8"
K	Wheel Face	4"
L	Overall Length Idler Roll	80"
M	Axle Height	8-7/8"
N	Wheel Height	14-7/8"
O	Frame Width Idler Roll	12-5/8"

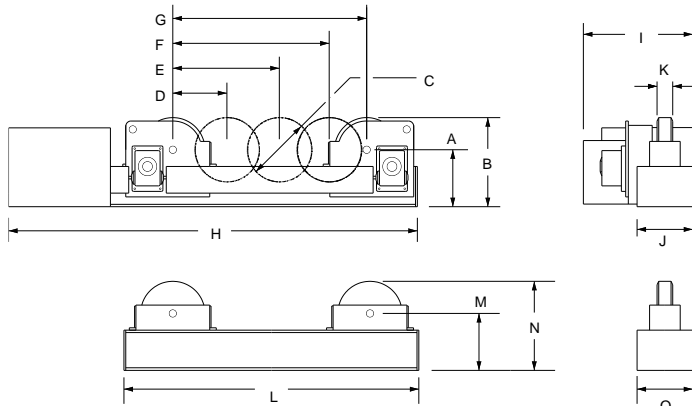

**Terms:** Pandjiris, Inc. standard terms and conditions apply, f.o.b. Factory, St. Louis, Missouri, or designated ship point.

**Delivery:** Consult Factory  
 Approximate shipping weight:  
 PR-10 625 lbs.  
 IR-5 250 lbs.

### PRICE LIST

For Bulletin No. : PW-1274-A  
 Effective Date : January 2014  
 Page Number : C-18-A1

**PANDJIRIS, INC**

5151 Northrup • St. Louis, MO 63110 • (314) 776-6893

**PR SERIES TURNING ROLLS  
Optional Accessories**

For steel wheels in place of rubber wheels, ..... Consult Factory

For foot switch with compatible plug for Forward/Stop/Reverse (speed potentiometer on hand pendant)

For foot switch, Fast-Slow with compatible plug

For preset digital tachometer with compatible plug reads speed in IPM or CmPM,

For 25' Extension Cable with compatible plugs for standard pendants and accessories

Tach feedback for precision speed control

For special voltages, PR-10/5 ..... Consult Factory

<p><b>PRICE LIST</b>  For Bulletin No. : PW-1274-A  Effective Date : January 2014  Page Number : C-18-A2</p>
--