

PANDJIRIS, INC

5151 Northrup • St. Louis, MO 63110 • (314) 776-6893

MODEL PR-480/120 TURNING ROLL

The **Model PR-480/120 Turning Roll** has a capacity of 240 tons turning and 60 tons support. It features Pandjiris' exclusive torque-tube wheel design sealed bearings, alloy shafts, and totally enclosed fan cooled (TEFC) motors with electronic drives. It comes with field changeable plug-in hand pendants including "Forward-Stop-Reverse-Weld/Rapid" buttons and a speed adjustment potentiometer on 25' of cable. All "PR" models have electronic variable speed controls infinitely variable between a specified range. The Rolls operate on 460 volt, three phase, 60 cycle input power, (230V available upon request). All wiring conforms to National Electrical Code Standards.

Turning Capacity	480,000 lbs.
Tractive Effort	22,171 lbs.
Load Capacity.....	120,000 lbs.
Pipe Diameter Range	12" thru 21'
Speed Range	4.5 to 39 ipm
Motor Type.....	AC Motor
Wheel Diameter	20" (Rubber Wheels with Overload Disc)
Combined Wheel Face.....	25"

The **Model IR-120 Idler Roll** has 60 tons support capacity.

Weight Capacity of IR-120	120,000 lbs.
Weight Capacity of (1) PR-480 with (1) IR-120	240,000 lbs.
Weight Capacity of (1) PR-480 with (2) IR-120	360,000 lbs.
Weight Capacity of (1) PR-480 with (3) IR-120	480,000 lbs.

A	Height	20"
B	Wheel Height	30-1/8"
C	Wheel Diameter	20"
D	Spacing for Cylinder Ø 36" - 108"	43"
E	Spacing for Cylinder Ø 60" - 153"	59-1/2"
F	Spacing for Cylinder Ø 102" - 202"	76"
G	Spacing for Cylinder Ø 160" - 252"	92-1/2"

H	Overall Length Power Roll	170-1/2"
I	Overall Width Power Roll	55-1/2"
J	Frame Width Power Roll	36"
K	Combined Wheel Face	25"
L	Overall Length Idler Roll	125-1/4"
M	Axle Height	20-1/8"
N	Wheel Height	30-1/8"
O	Frame Width Idler Roll	36"

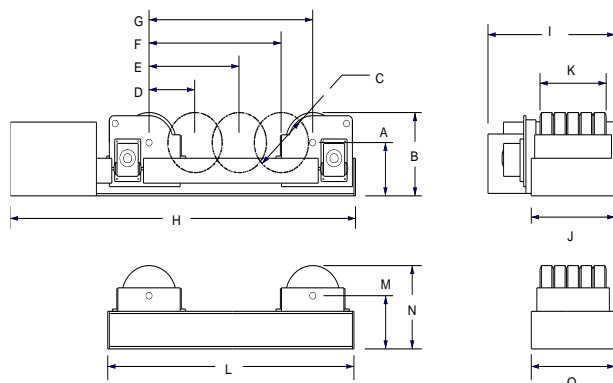

Terms: Pandjiris, Inc. standard terms and conditions apply, f.o.b. Factory, St. Louis, Missouri, or designated ship point.

Delivery: Consult Factory
Approximate shipping weight:

PR-480	7,100 lbs.
IR-120	3,95

PRICE LIST	
For Bulletin No. :	N/A
Effective Date :	Jan., 2014
Page Number :	C-31

PANDJIRIS, INC

5151 Northrup • St. Louis, MO 63110 • (314) 776-6893

**PR SERIES TURNING ROLLS
Optional Accessories**

- For steel wheels in place of rubber wheelsConsult Factory
- For foot switch with compatible plug for Forward/Stop/Reverse (speed potentiometer on hand pendant)
- For foot switch, Fast-Slow with compatible plug
- For preset digital tachometer with compatible plug reads speed in IPM or CmPM
- For 25' Extension Cable with compatible plugs for standard pendants and accessories
- For special voltages, PR-400/200 thru PR-480/120, AddConsult Factory

PRICE LIST	
For Bulletin No. :	N/A
Effective Date :	June, 2008
Page Number :	C-32