

PANDJIRIS, INC

5151 Northrup • St. Louis, MO 63110 • (314) 776-6893

TANKER 150/75 TURNING ROLL

The **Tanker 150 Power Roll, Model TPR-150** has a capacity of 15,000 lbs. turning and 7,500 lbs. support. An electronic variable speed drive allows a welding speed of 4.7 to 94.5 IPM with a field changeable plug-in hand pendant. This includes "Forward-Stop-Reverse-Weld/Rapid" buttons and a speed adjustment potentiometer on 25' of cable to handle workpieces from 3-1/2" to 144" diameter. The standard electricals are 115 volts, single phase, 60 cycle, draws 10 amps. Wired to the National Electrical Code Standards.

Turning Capacity 15,000 lbs.
 Tractive Effort 693 lbs.
 Load Capacity 7,500 lbs.
 Pipe Diameter Range 3.5" thru 144"
 Speed Range 4.7 to 94.5 IPM
 Motor Horse Power Rating 1/2 HP
 Wheel Diameter 16"
 Combined Wheel Face 4"

The **TIR/75 Tanker 75 Idler Roll** has 7,500 lbs. support capacity.

Weight Capacity of TIR/75 Idler Roll 7,500 lbs
 Weight Capacity of (1) TPR/150 Power Roll with (1) TIR/75 Idler Roll 15,000 lbs

| POWER ROLL | | |
|------------|---------------------|---------------|
| A | Wheel Height | 17-1/4" & 26" |
| B | Wheel Diameter | 16" |
| C | Wheel Face | 4" |
| D | Pipe Diameter Range | 3-1/2" - 144" |
| E | Frame Length | 64" |
| F | Frame Width | 20" |

| IDLER ROLL | | |
|------------|---------------------|---------------|
| A | Wheel Height | 17-1/4" & 26" |
| B | Wheel Diameter | 16" |
| C | Wheel Face | 4" |
| D | Pipe Diameter Range | 3-1/2" - 144" |
| E | Frame Length | 64" |
| F | Frame Width | 18" |

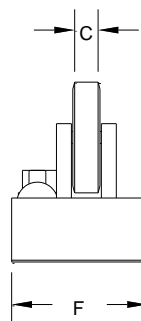
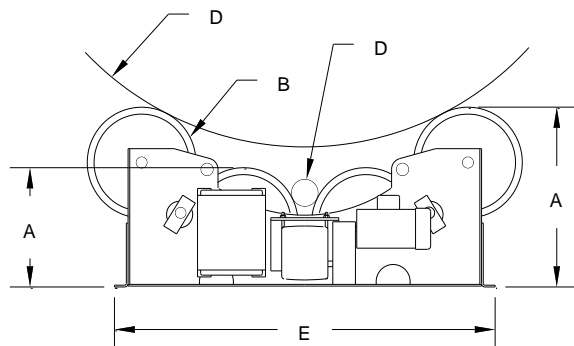

Terms: Pandjiris, Inc. standard terms and conditions apply, f.o.b. Factory, St. Louis, Missouri, or designated ship point.

Delivery: Consult Factory
 Approximate shipping weight:
 Power Roll 700 lbs.
 Idler Roll 500 lbs.

PRICE LIST

For Bulletin No. : Tanker 593
 Effective Date : January 2014
 Page Number : C-9

PANDJIRIS, INC

5151 Northrup • St. Louis, MO 63110 • (314) 776-6893

TANKER TURNING ROLL Optional Accessories

For foot switch with compatible plug for Forward/Stop/Reverse (speed potentiometer on hand pendant)

For foot switch, Fast-Slow with compatible plug

For preset digital tachometer with compatible plug reads speed in IPM or CmPM

(4) V-groove wheels on Power Roll, includes modification to frame

(4) V-groove wheels on Idler, includes modification to frame

Riser pad for use on Power Roll with Idler on track

Model "VT" V-track, 10 ft. sections

For special voltages

For 25' Extension Cable with compatible plugs for standard pendants and accessories

PRICE LIST

For Bulletin No. : Tanker 593
Effective Date : January 2014
Page Number : C-10