

# PANDJIRIS, INC

5151 Northrup • St. Louis, MO 63110 • (314) 776-6893

## SUPER PIPER 10/5 TURNING ROLL

The **Model Super Piper 10/5 Power Roll** has a capacity of 10,000 lbs. turning and 5,000 lbs. weight capacity, steel wheels with positive gear drive. An electronic variable speed drive allows a welding speed of 6.1 to 184 IPM with a field changeable plug-in hand pendant. This includes "Forward-Stop-Reverse-Weld/Rapid" buttons and a speed adjustment potentiometer on 25' of cable to handle workpieces from 10" to 48" diameter. The standard electricals are 115 volts, single phase, 60 cycle, draws 6.5 amps. Wired to conform to the National Electrical Code Standards.

Turning Capacity ..... 10,000 lbs.  
 Tractive Effort ..... 312 lbs  
 Load Capacity ..... 5,000 lbs.  
 Pipe Diameter Range ..... 10" thru 48"  
 Speed Range ..... 6.1 to 184 ipm  
 Motor Horse Power Rating ..... 1/3 HP  
 Wheel Diameter ..... 12" (Steel Wheel)  
 Combined Wheel Face ..... 1-7/8"

The **SI/5 Idler Roll** has 5,000 lbs. support capacity.

Weight Capacity of SI/5 Idler Roll .....5,000 lbs  
 Weight Capacity of (1) SP/10 Power Roll with (1) SI/5 Idler Roll .....10,000 lbs

| POWER ROLL |                     |           |
|------------|---------------------|-----------|
| A          | Wheel Height        | 15"       |
| B          | Wheel Diameter      | 12"       |
| C          | Wheel Face          | 1-7/8"    |
| D          | Pipe Diameter Range | 10" - 48" |
| E          | Frame Length        | 37-3/4"   |
| F          | Frame Width         | 17"       |
| G          | Overall Height      | 19-5/16"  |

| IDLER ROLL |                     |           |
|------------|---------------------|-----------|
| H          | Wheel Height        | 15"       |
| I          | Wheel Diameter      | 12"       |
| J          | Wheel Face          | 2"        |
| K          | Pipe Diameter Range | 10" - 48" |
| L          | Frame Length        | 32"       |
| M          | Frame Width         | 6"        |
| N          | Frame Height        | 19-5/16"  |

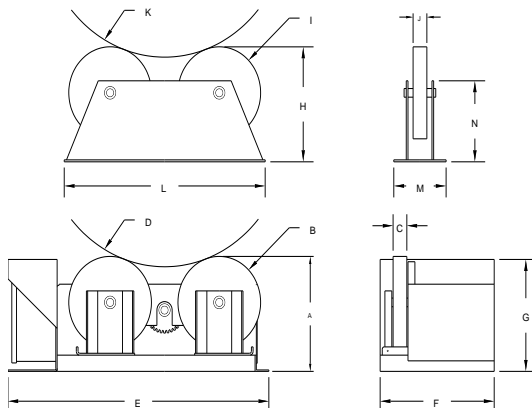

**Terms:** Pandjiris, Inc. standard terms and conditions apply, f.o.b. Factory, St. Louis, Missouri, or designated ship point.

**Delivery:** Consult Factory  
 Approximate shipping weight:  
 Power Roll 400 lbs.  
 Idler Roll 250 lbs.

| PRICE LIST       |             |
|------------------|-------------|
| For Bulletin No. | : PW-4073   |
| Effective Date   | : May, 2017 |
| Page Number      | : C-5       |

# PANDJIRIS, INC

5151 Northrup • St. Louis, MO 63110 • (314) 776-6893

## **SUPER PIPER TURNING ROLL Optional Accessories**

For foot switch with compatible plug for Forward/Stop/Reverse (speed potentiometer on hand pendant)

For foot switch, Fast-Slow with compatible plug

For preset digital tachometer with compatible plug reads speed in IPM or CmPM

Hold-down for 3-1/2" to 36" diameters

For less than 10" dia. workpiece, SP/10-3.5 steel wheel adapter to power unit

For less than 10" dia. workpiece, SI/5-3.5 steel wheel adapter to idler

For 25' Extension Cable with compatible plugs for standard pendants and accessories

For special voltages, add .....Consult Factory

### **PRICE LIST**

For Bulletin No. : 51566-A/493  
Effective Date : January 2014  
Page Number : C-6